



CLPX-Airborne: Polarimetric Ku-Band Scatterometer (POLSCAT) Data, Version 1

USER GUIDE

How to Cite These Data

As a condition of using these data, you must include a citation:

Yueh, S. 2003. *CLPX-Airborne: Polarimetric Ku-Band Scatterometer (POLSCAT) Data, Version 1*. [Indicate subset used]. Boulder, Colorado USA. NASA National Snow and Ice Data Center Distributed Active Archive Center. <https://doi.org/10.5067/UHA2RPUMRDJ4>. [Date Accessed].

FOR QUESTIONS ABOUT THESE DATA, CONTACT NSIDC@NSIDC.ORG

FOR CURRENT INFORMATION, VISIT <https://nsidc.org/data/NSIDC-0159>



National Snow and Ice Data Center

TABLE OF CONTENTS

1	DETAILED DATA DESCRIPTION.....	2
1.1	Format	2
1.2	File and Directory Structure.....	2
1.3	File Naming Convention	3
1.4	File Size.....	3
1.5	Spatial Coverage.....	3
1.6	Temporal Coverage.....	3
1.7	Parameter or Variable	3
2	DATA ACQUISITION AND PROCESSING.....	3
2.1.1	POLSCAT Key Parameters	4
2.2	Flight Summaries.....	5
2.2.1	2002 Flight Summary.....	5
2.2.2	2003 Flight Summary.....	10
3	REFERENCES AND RELATED PUBLICATIONS	12
3.1	RELATED DATA COLLECTIONS.....	12
4	CONTACTS AND ACKNOWLEDGMENTS	12
4.1	Acknowledgments	13
5	DOCUMENT INFORMATION.....	13
5.1	Publication Date	13
5.2	Date Last Updated.....	13

1 DETAILED DATA DESCRIPTION

1.1 Format

The raw data from POLSCAT/CLPX flights have been processed to produce the normalized radar cross section (σ_0) of the terrain. Data from each flight line are saved in a fixed-width ASCII text file containing 24 columns, of which only the first 12 are relevant to CLPX:

Column 1: POLSCAT instrument time in sec (UT time) from the beginning of the day

Column 2: Aircraft GPS time in sec (UT) from the beginning of the day

Column 3: Latitude of the antenna footprint in degrees

Column 4: Longitude of the antenna footprint in degrees

Column 5: Azimuth angle of the vector from the antenna to the antenna footprint (0 degrees at north)

Column 6: Polarization roll angle in degrees

Column 7: Range from the antenna footprint to aircraft in meters

Column 8: Incidence angle in degrees

Column 9: σ_{VV} in dB, the σ_0 for vertically polarized transmit and vertically polarized receive

Column 10: σ_{HH} in dB, the σ_0 for horizontally polarized transmit and horizontally polarized receive

Column 11: σ_{HV} in dB, the σ_0 for vertically polarized transmit and horizontally polarized receive

Column 12: σ_{VH} in dB, the σ_0 for horizontally polarized transmit and vertically polarized receive

Note that σ_{HV} is supposed to be identical to σ_{VH} . The measurements agree with this expectation very well; the difference between measured σ_{HV} and σ_{VH} is within 0.2 dB most of the time, which is within the sensitivity of the POLSCAT system operating on the DC-8 aircraft.

1.2 File and Directory Structure

```
2002/
  polscat-0219/
    02191615.red, etc.
  polscat-0221/
  polscat-0223/
  polscat-0325/
2003/
  polscat-0325/
    03251230.red, etc.
  polscat-0328/
  polscat-0330/
```

1.3 File Naming Convention

Each data file has eight numbers in its filename, incorporating the date and time of data collection (mmdhmm). The first four numbers of the filename represent the month 'mm' and day of month 'dd' and the last four indicate the start time (UT) of each flight line (hhmm). For example, the filename of a flight line commencing at 16:15 on 19 February is 02191615. Files are in directories by year (2002 and 2003).

1.4 File Size

Files range in size from 1 to 114 KB.

1.5 Spatial Coverage

Flights were flown over the Fraser, North Park, and Rabbit Ears MSAs of the CLPX. Flight lines are matched to data files in the Flight Summaries section of this document.

1.6 Temporal Coverage

Three flights were flown on 19, 21, and 23 February 2002 during IOP1. Another flight was flown on 25 March 2002, when the DC-8 made a transit from Wisconsin to California (which coincided with IOP2). In 2003, three flights were flown on 25, 28 and 30 March during IOP 4.

1.7 Parameter or Variable

The parameter presented in this data set is backscatter return from a Ku-band polarimetric scatterometer, measured in decibels (dB). This is not a direct measurement of SWE.

2 DATA ACQUISITION AND PROCESSING

POLSCAT is a Ku-band polarimetric scatterometer operating at 13.95 GHz. The transmitting polarization of POLSCAT is alternated between vertical (V) and horizontal (H) from pulse to pulse. Two receivers detect the V- and H-polarized radar echoes simultaneously. Each receiver down-converts the frequency of the backscatter signals and provides in-phase (I) and quadrature-phase (Q) components for data acquisition.

The POLSCAT antenna, mounted on a 62-degree port in the DC-8, pointed approximately in the center of the JPL Airborne Synthetic Aperture Radar (AIRSAR) swath. The front-end radio

frequency box, where the calibration loop is located, was temperature-controlled to $35^{\circ}\pm 0.1^{\circ}\text{C}$ to achieve 0.1 dB calibration stability.

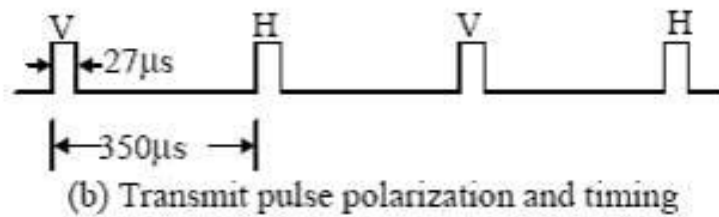
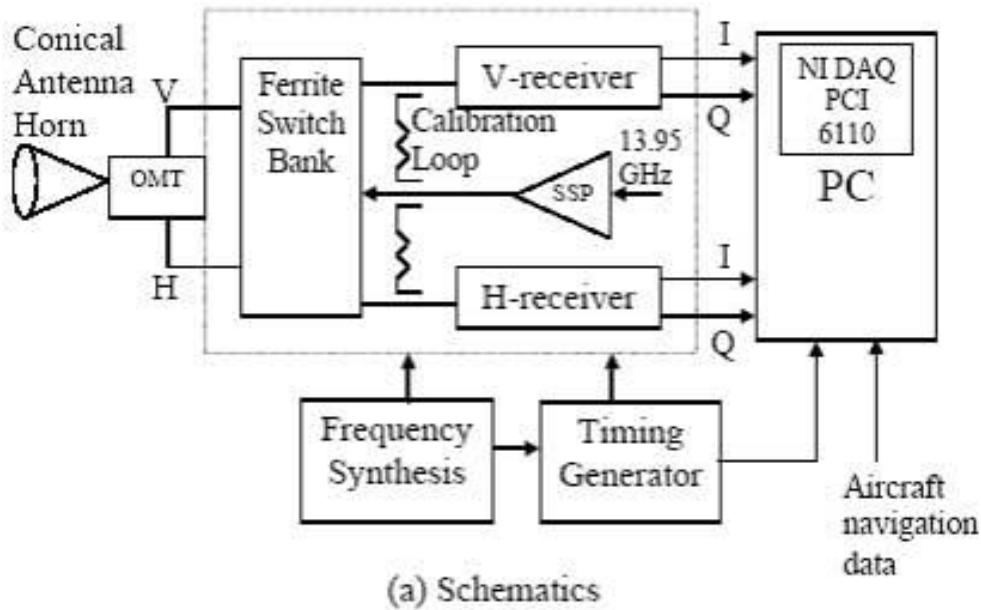

Raw data from POLSCAT flights have been processed to produce the normalized radar cross section of the terrain. The range from the target to the antenna was calculated using the aircraft altitude, aircraft GPS altitude, and a digital elevation map.

In-flight calibration was performed using a calibration loop consisting of one waveguide attenuator and two directional waveguide couplers in the radar front-end, which leaks a small transmit signal into the receivers. Tests conducted in the laboratory, and aircraft flight data, suggest that the calibration loop measurements are very stable, with a drift of less than 0.1 dB over several hours. The key parameters of POLSCAT are described in the following table.

2.1.1 POLSCAT Key Parameters

* Actual incidence angle depends on the aircraft attitude

Parameter	Characteristics
Frequency	13.95 GHz
Polarization	VV, HH, HV, VH
Nominal Incidence Angle*	40°
Antenna Beamwidth	5°
Antenna Peak Gain	28 dB
Antenna Sidelobe	<-30 dB
Polarization Isolation	>35 dB
Footprint size	1 km x 0.7 km at 8 km altitude
Radar Transmit Peak Power	6 W at OMT flange
Radar Transmit PRF	2857 Hz
Radar Transmit Pulse Length	27 μs
Noise Equivalent σ_0	-35 dB at 8 km altitude
Receiver A/D Converter	12 bits

2.2 Flight Summaries

The following tables summarize data from all the flight lines over the CLPX intensive study areas (ISAs).

Column 1 indicates the day of data acquisition

Column 2 is the filename for the data from each flight line

Column 3 is the name of flight line

Column 4 is the nominal above-ground flight altitude

Column 5 is the ISA.

2.2.1 2002 Flight Summary

Date	Filename	Flight Line	Nominal Altitude (ft)	Remark
19 February 2002	02191615	NP270-1	26000	North Park
	02191626	NP90-1	26000	North Park
	02191637	NP270-2	26000	North Park
	02191650	NP360-1	26000	North Park
	02191703	NP270-3	26000	North Park
	02191715	NP90-2	26000	North Park

Date	Filename	Flight Line	Nominal Altitude (ft)	Remark
	02191726	NP270-4	26000	North Park
	02191744	NP282-1	26000	North Park
	02191800	RE270-1	26000	Rabbit Ears
	02191810	RE90-1	26000	Rabbit Ears
	02191821	RE270-2	26000	Rabbit Ears
	02191834	RE180-1	26000	Rabbit Ears
	02191851	RE270-3	26000	Rabbit Ears
	02191902	RE90-2	26000	Rabbit Ears
	02191913	RE270-4	26000	Rabbit Ears
	02191925	RE90-3	26000	Rabbit Ears
	02191942	FR270-1	26000	Fraser
	02191953	FR90-1	26000	Fraser
	02192003	FR270-2	26000	Fraser
	02192017	FR360-1	26000	Fraser
	02192030	FR270-3	26000	Fraser
	02192041	FR90-2	26000	Fraser
	02192054	FR270-4	26000	Fraser
	02192119	PSR RE-1	5000	Rabbit Ears
	02192131	PSR RE-2	5000	Rabbit Ears
	02192140	PSR RE-3	5000	Rabbit Ears
	02192151	PSR RE-4	5000	Rabbit Ears
	02192202	PSR RE-5	5000	Rabbit Ears
	02192213	PSR RE-6	5000	Rabbit Ears
	02192224	PSR RE-7	5000	Rabbit Ears
21 February 2002	02211648	PSR FR-1 (AA 270-1)	5000	Fraser, Partly cloudy
	02211658	PSR FR-2 (AA90-1)	5000	Fraser
	02211710	PSR FR-3 (AA270-2)	5000	Fraser
	02211720	PSR FR-4 (AA90-2)	5000	Fraser
	02211731	PSR FR-5 (AA270-3)	5000	Fraser
	02211742	PSR FR-6 (AA90-3)	5000	Fraser

Date	Filename	Flight Line	Nominal Altitude (ft)	Remark
	02211754	PSR FR-7 (AA270-4)	5000	Fraser
	02211801	Way pt 17-18	5000	Transit
	02211811	PSR RE-2-180 (CC270-1)	5000	Rabbit Ears
	02211820	PSR RE-6 (CC90-1)	5000	Rabbit Ears
	02211833	PSR NP-5 (BB270-1)	5000	North Park
	02211844	PSR NP-4 (BB90-1)	5000	North Park
	02211933	NP270-1	26000	North Park
	02211944	NP90-1	26000	North Park
	02211955	NP270-2	26000	North Park
	02212010	NP360-1	26000	North Park
	02212023	NP270-3	26000	North Park
	02212034	NP90-2	26000	North Park
	02212045	NP270-4	26000	North Park
	02212104	NP282-1	26000	North Park
	02212123	RE270-1	26000	Rabbit Ears
	02212134	RE90-1	26000	Rabbit Ears
	02212145	RE270-2	26000	Rabbit Ears
	02212159	RE180-1	26000	Rabbit Ears
	02212214	RE270-3	26000	Rabbit Ears
	02212225	RE90-2	26000	Rabbit Ears
	02212236	RE270-4	26000	Rabbit Ears
	02212247	RE90-3	26000	Rabbit Ears
	02212305	FR270-1	26000	Fraser
	02212316	FR90-1	26000	Fraser
	02212327	FR270-2	26000	Fraser
	02212341	FR360-1	26000	Fraser
	02212356	FR270-3	26000	Fraser
	02220007	FR90-2	26000	Fraser
	02220021	FR270-4	26000	Fraser

Date	Filename	Flight Line	Nominal Altitude (ft)	Remark
23 February 2002	02231642	PSR FR-55	5000	Fraser
	02231652	PSR FR-3-180	5000	Fraser
	02231709	PSR RE-2-180	5000	Rabbit Ears
	02231718	PSR RE-6	5000	Rabbit Ears
	02231731	PSR NP-1	5000	North Park
	02231741	PSR NP-2	5000	North Park
	02231754	PSR NP-3	5000	North Park
	02231806	PSR NP-4	5000	North Park
	02231818	PSR NP-5	5000	North Park
	02231828	PSR NP-6	5000	North Park
	02231840	PSR NP-7	5000	North Park
	02231915	NP270-1	26000	North Park
	02231926	NP90-1	26000	North Park
	02231939	NP270-2	26000	North Park
	02231953	NP360-1	26000	North Park
	02232005	NP270-3	26000	North Park
	02232017	NP90-2	26000	North Park
	02232028	NP270-4	26000	North Park
	02232048	NP282-1	26000	North Park
	02232104	RE270-1	26000	Rabbit Ears
	02232118	RE90-1	26000	Rabbit Ears
	02232128	RE270-2	26000	Rabbit Ears
	02232140	RE180-1	26000	Rabbit Ears
	02232155	RE270-3	26000	Rabbit Ears
	02232206	RE90-2	26000	Rabbit Ears
	02232217	RE270-4	26000	Rabbit Ears
	02232229	RE90-3	26000	Rabbit Ears
	02232252	FR270-1	26000	Fraser
	02232302	FR90-1	26000	Fraser
	02232313	FR270-2	26000	Fraser
	02232327	FR360-1	26000	Fraser
	02232339	FR270-3	26000	Fraser

Date	Filename	Flight Line	Nominal Altitude (ft)	Remark
	02232351	FR90-2	26000	Fraser
	02240003	FR270-4	26000	Fraser
25 March 2002	03251926	NP270-1	26000	North Park
	03251937	NP90-1	26000	North Park
	03251956	NP270-2	26000	North Park
	03252011	NP360-1	26000	North Park
	03252024	NP270-3	26000	North Park
	03252035	NP90-2	26000	North Park
	03252046	NP270-4	26000	North Park
	03252104	NP282-1	26000	North Park
	03252120	RE270-1	26000	Rabbit Ears
	03252131	RE90-1	26000	Rabbit Ears
	03252142	RE270-2	26000	Rabbit Ears
	03252155	RE180-1	26000	Rabbit Ears
	03252211	RE270-3	26000	Rabbit Ears
	03252223	RE90-2	26000	Rabbit Ears
	03252234	RE270-4	26000	Rabbit Ears
	03252246	RE90-3	26000	Rabbit Ears
	03252304	FR270-1	26000	Fraser
	03252315	FR90-1	26000	Fraser
	03252326	FR270-2	26000	Fraser
	03252340	FR360-1	26000	Fraser
	03252353	FR270-1	26000	Fraser
	03260003	FR90-2	26000	Fraser
	03260015	FR270-3	26000	Fraser
	03260035	FR270-4	26000	Fraser
	03260116	GS01B	26000	Sand Dunes
	03260127	GS02B	26000	Sand Dunes
	03260240	Criver	26000	Colorado River

2.2.2 2003 Flight Summary

Date	Filename	Flight Line	Nominal AG Altitude (ft)	Remark
25 March 2003	03251209	NP270-1	26000	North Park; DC-8 ICAT Failed
	03251244	NP360-1	26000	North Park
	03251258	NP270-3	26000	North Park
	03251308	NP90-2	26000	North Park
	03251318	NP270-4	26000	North Park
	03251337	NP282-1	26000	North Park
	03251343		26000	wing wag
	03251402	RE270-1	26000	Rabbit Ears
	03251412	RE90-1	26000	Rabbit Ears
	03251422	RE270-2	26000	Rabbit Ears
	03251436	RE180-1	26000	Rabbit Ears
	03251504	RE270-3	26000	Rabbit Ears
	03251516	RE90-2	26000	Rabbit Ears
	03251528	RE270-4	26000	Rabbit Ears
	03251538	RE90-3	26000	Rabbit Ears
	03251555	FR270-1	26000	Fraser
	03251605	FR90-1	26000	Fraser
	03251616	FR270-2	26000	Fraser
	03251629	FR360-1	26000	Fraser
	03251643	FR270-3	26000	Fraser
	03251653	FR90-2	26000	Fraser
	03251707	FR270-4	26000	Fraser
	03251720	FR180-1 option	26000	Fraser
	03251731	FR Orbit	26000	Fraser ISA, -30 deg roll
	03251753	315-1	26000	Hayman Fire Scar
	03251806		26000	Negative 60 deg roll
28 March 2003	03281157	NP270-1	26000	North Park
	03281207	NP90-1	26000	North Park; Mouse touched keypad and interrupted polscat acquisition
	03281218	NP270-2	26000	North Park

Date	Filename	Flight Line	Nominal AG Altitude (ft)	Remark
	03281233	NP360-1	26000	North Park
	03281246	NP270-3	26000	North Park
	03281257	NP90-2	26000	North Park
	03281307	NP270-4	26000	North Park
	03281325	NP282-1	26000	North Park
	03281339	NP Orbit E-W	26000	North Park
	03281348	NP Orbit N-S	26000	North Park
	03281356	NP Option 90-1	26000	North Park
	03281402	Windrad cal	26000	wing wag-pitch
	03281430	RE90-1	26000	Rabbit Ears
	03281439	RE270-2	26000	Rabbit Ears
	03281452	RE180-1	26000	Rabbit Ears
	03281507	RE270-3	26000	Rabbit Ears
	03281517	RE90-2	26000	Rabbit Ears
	03281527	RE270-4	26000	Rabbit Ears
	03281537	RE90-3	26000	Rabbit Ears
	03281604	FR90-1	26000	Fraser
	03281614	FR270-2	26000	Fraser
	03281627	FR360-1	26000	Fraser
	03281645	FR270-3	26000	Fraser
	03281656	FR90-2	26000	Fraser
	03281709	FR270-4	26000	Fraser
30 March 2003	03301207	NP270-1	26000	North Park; Thin scattered low-level clouds
	03301217	NP90-1	26000	North Park
	03301227	NP270-2	26000	North Park
	03301241	NP360-1	26000	North Park
	03301254	NP270-3	26000	North Park
	03301304	NP90-2	26000	North Park
	03301315	NP270-4	26000	North Park
	03301332	NP282-1	26000	North Park
	03301340	wing wag		Transit
	03301352	RE270-1	26000	Rabbit Ears
	03301402	RE90-1	26000	Rabbit Ears

Date	Filename	Flight Line	Nominal AG Altitude (ft)	Remark
	03301412	RE270-2	26000	Rabbit Ears
	03301426	RE180-1	26000	Rabbit Ears
	03301440	RE270-3	26000	Rabbit Ears
	03301450	RE90-2	26000	Rabbit Ears
	03301500	RE270-4	26000	Rabbit Ears
	03301511	RE90-3	26000	Rabbit Ears
	03301523	RE Option 70-1 (270)	26000	Rabbit Ears
	03301534	RE Option Orbit S-N	26000	Rabbit Ears
	03301543	RE Option Orbit W-E	26000	Rabbit Ears
	03301606	FR90-1	26000	Fraser
	03301617	FR270-2	26000	Fraser
	03301631/1633	FR360-1	26000	Fraser
	03301643	FR270-3	26000	Fraser
	03301654	FR90-2	26000	Fraser
	03301705	FR270-4	26000	Fraser
	03301718	FR Option Orbit S-N	26000	Fraser
	03301726		26000	

3 REFERENCES AND RELATED PUBLICATIONS

Yueh, Simon H., William J. Wilson, and Steve Dinardo. 2002. Polarimetric Radar Remote Sensing of Ocean Surface Wind. *IEEE Trans. Geosci. Remote Sens.* 40(4): 793-800.

3.1 RELATED DATA COLLECTIONS

- [All CLPX Data Sets](#)
- [CLPX-Ground: Ground-based L and Ku Band Polarimetric Scatterometry](#)

4 CONTACTS AND ACKNOWLEDGMENTS

Simon H. Yueh

Jet Propulsion Laboratory

M/S 300-233

Pasadena, CA 91109 USA

4.1 Acknowledgments

This research was carried out by the Jet Propulsion Laboratory, California Institute of Technology, under a contract with the National Aeronautics and Space Administration.

5 DOCUMENT INFORMATION

5.1 Publication Date

8 January 2004

5.2 Date Last Updated

6 April 2021