



National Snow and Ice Data Center
SUPPORTING CRYOSPHERIC RESEARCH SINCE 1979

Handbook for community-based sea ice monitoring

Special Report #14

30 June 2008

Andy Mahoney and Shari Gearheard

National Snow and Ice Data Center
Cooperative Institute for Research in Environmental Sciences
University of Colorado, Boulder, Colorado, USA

Contents

Contents	i
Foreword	iii
A Note on Safety	iii
Acknowledgments	iv
Citation	v
Introduction	1
Chapter 1: Measuring ice thickness by drilling	2
1.1 Before leaving land	2
1.2 The Kovacs Auger	2
1.3 Drilling a hole	3
1.4 Measuring snow depth, ice thickness, and freeboard	4
1.5 Measuring water depth	4
Chapter 2: Installation of ice and snow measurement site	6
2.1 Before leaving land	6
2.2 Choosing a site	6
2.3 Laying out the site	7
2.4 Installing a hotwire gauge	7
2.5 Installing a snow stake	8
2.6 Installing the copper ground wire	9
Chapter 3: Hotwire measurements of ice thickness and snow depth	10
3.1 Before leaving land	10
3.2 Reading the snow stakes	10
3.3 Measuring sea ice thickness with the hotwire gauges	11
3.4 Troubleshooting the hotwire gauges	13
3.5 Measuring snow depth or sea ice melt at the hotwire gauges	13
Chapter 4: Measuring sea ice surface and snow temperature	15
4.1 Before leaving land	15
4.2 Digging a snow pit	15
4.3 Measuring ice surface temperature	15
4.4 Measuring snow temperature	16
Chapter 5: Retrieving the stakes and cables	17
5.1 Before leaving land	17
5.2 When and how to retrieve the equipment	17
5.3 Storage during summer	17
Chapter 6: Simple Data Analysis	18
Appendix 1 : Constructing the necessary equipment	19
6.1 Making a snow stake	19
6.2 Constructing the stakes for the hotwire gauges	22
6.3 Constructing the cables for the hotwire gauges	23
6.4 Making the connector wires	24
6.5 Building a water depth gauge	24
6.6 Hardware recommendations	25
Appendix 2 : Data Recording Sheets	26
Hotwire gauge and snow stake data recording sheet	27

Handbook for community-based sea ice monitoring

Drill hole ice data recording sheet.....	28
Ice and snow temperature data recording sheet.....	29
Appendix 3 : Sea ice monitoring in action.....	30

Foreword

This handbook was originally compiled as a reference for local observers carrying out sea ice measurements as part of a community-based sea ice observation network for the *Siku-Inuit-Hila* project, an NSF-funded project (2006-2010) examining sea ice, sea ice use, and sea ice change at the Arctic communities of Qaanaaq, Greenland, Barrow, Alaska, and Clyde River, Nunavut.

In response to interest from other communities and researchers, we are now making the handbook available as a resource for anyone wishing to establish a local sea ice monitoring program. The methods and equipment described were chosen with remote communities of the Arctic in mind. They should allow communities to acquire high quality data without requiring specialist training or experience. They are also intended to be robust and simple to build or repair. Although there can be no substitute for hands-on practice and training, this handbook is intended to contain complete instructions for assembling the necessary equipment and using it to monitor sea ice and snow. We leave it to individual investigators to decide upon the specific design elements of a monitoring program such as numbers and locations of stations and measurement frequencies. However, we recommend obtaining advice from local experts concerning these aspects.

An Inuktitut version of this handbook is available through NSIDC User Services at nsidc@nsidc.org.

A Note on Safety

This handbook contains suggested methods for monitoring sea ice. It is intended for use by experienced Arctic residents who have extensive skills and knowledge related to sea ice travel. We do not recommend traveling on sea ice unless you have the appropriate skills and knowledge, or you are accompanied by someone who does.

Acknowledgments

The “hotwire” technique we describe for measuring sea ice thickness was originally devised by Norbert Untersteiner and Franklin Badgley (both emeriti of the University of Washington, Seattle). The design of the monitoring stations was taken from those used by Hajo Eicken (University of Alaska Fairbanks), Don Perovich (Cold Regions Research and Engineering Laboratory, Hanover, New Hampshire), and others. We are grateful to local sea ice observers Toku Oshima and Mamarut Kristiansen (Qaanaaq, Greenland), and Teema Qillaq (Clyde River, Nunavut) who provided valuable feedback and advice based on their own experiences using the techniques and equipment we have described. The *Siku-Inuit-Hila* project was made possible by a grant from the National Science Foundation (HSD 0624344). We also thank the National Snow and Ice Data Center for publishing this handbook as a special report.

Cover photo: Mamarut Kristiansen installs a sea ice monitoring station near his community Qaanaaq, Greenland (photo by Shari Gearheard).

Citation

Mahoney, A. and Gearheard, S., 2008, Handbook for community-based sea ice monitoring, NSIDC Special Report 14, Boulder, CO, USA: National Snow and Ice Data Center. http://nsidc.org/pubs/special/nsidc_special_report_14.pdf

For additional information, or if you have questions about this document, please contact NSIDC User Services at nsidc@nsidc.org.

Introduction

This guide describes standardized methods for measuring sea ice thickness and snow depths in the context of a long-term monitoring program. Ice thickness and snow depth are two of the most important properties of the ice cover. The thickness of ice determines its strength and the amount of snow on top affects how quickly the ice grows. In this guide, we describe two ways to measure sea ice thickness and snow depth. We also explain how to measure the temperature of the ice and snow. By keeping to the methods described here, you will ensure that the data are consistent and can be easily compared with measurements taken elsewhere and at different times.

Chapter 1 describes how to drill through the sea ice to measure ice thickness, snow depth, freeboard, and water depth. We provide a sheet for you to record all the measurements along with the date and location. Many holes can be drilled during a single trip onto the ice in order to see how much the sea ice varies from one location to another. However, each time a hole is drilled it disturbs the ice and snow so future measurements may be affected. Chapters 2 and 3 describe how to install an ice station where repeated measurements can be taken without disturbing the ice cover each time. This is vital for a reliable long-term program to measure growth and melt. In Chapter 4, we describe how to measure the surface temperature of the ice and the temperature of the snow at different depths. Chapter 5 describes how to retrieve the equipment from the sea ice and store it over the summer.

In each of these chapters, there are different sub-sections that describe the steps involved. The first sub-section in each chapter is called “Before leaving land” and contains a brief description of the chapter and a list of equipment that will be needed. We suggest thoroughly reading each chapter before going out on the sea ice so that you are familiar with the tasks and equipment needed. At the end of the handbook, there are two appendices. Appendix 1 contains instructions for making all of the necessary monitoring equipment. Appendix 2 contains data recording sheets that you can print or photocopy to meet your needs. Appendix 3 contains photographs showing different aspects of installing and monitoring, in action.

Chapter 1: Measuring ice thickness by drilling

1.1 Before leaving land

This section describes how to use a Kovacs auger and an ice thickness tape to drill through the ice and measure ice thickness, freeboard, snow depth, and water depth. Drilling a hole can be very quick and it is possible to drill many holes over a wide area in a short time. Each time a hole is drilled, please record the following pieces of information (you can use the recording sheet we provide in Appendix 2):

- Time and date
- Location
- Ice thickness
- Snow depth
- Freeboard
- Water depth
- Any other information about the location you feel is important

The sections below describe how to take these measurements. Please read them before going on the ice. In order to drill holes and make these measurements, you will need the following equipment:

- Kovacs auger
- Electric drill
- Extension power cord
- Generator
- Ice thickness tape measure
- Ruler
- Water depth gauge
- Shovel
- Notebook / pencil
- Data recording sheet
- Bottle of water (~ 1 liter / 1 qt.)
- GPS
- Digital camera

1.2 The Kovacs Auger

The Kovacs auger is an efficient tool for drilling through ice. The cutting edge is sharp and care should be taken not to damage it or other objects (including yourself!) while using it or transporting it. The auger comes with additional flights that can be attached to the auger to drill through thick ice. Each flight is 1 m (3 ft, 4 in) long. The auger can be powered either by hand, using the brace attachment, or by an electric drill using the drill adapter. The electric drill will need to be powered by the generator. Note that the

drill adapter has a disc that will prevent the auger falling from through the ice if it becomes detached from the drill.

1.3 Drilling a hole

Unless you are very tall, or have something to stand on, you will find it easiest to begin drilling with just one flight attached to the auger. If the snow is deeper than a few centimeters (an inch or two) you will need to clear the snow from a small area around the place you intend to drill. While drilling, remove the ice chippings that come out of the hole. When you need to attach another flight, disconnect the drill adapter from the top of the flight, attach the next flight and reconnect the drill adapter. **(Note: Hold tightly to the auger in the hole while doing this in case it should fall though the ice.)** As you approach the bottom of the ice, you will notice the drilling become easier. When the drill goes through the ice, pull up and down a few times to flush the ice chippings from hole and remove the auger completely before disconnecting. This reduces the risk of dropping the auger through the hole. Finally, when back on land, please rinse the auger to remove salt and reduce rusting.

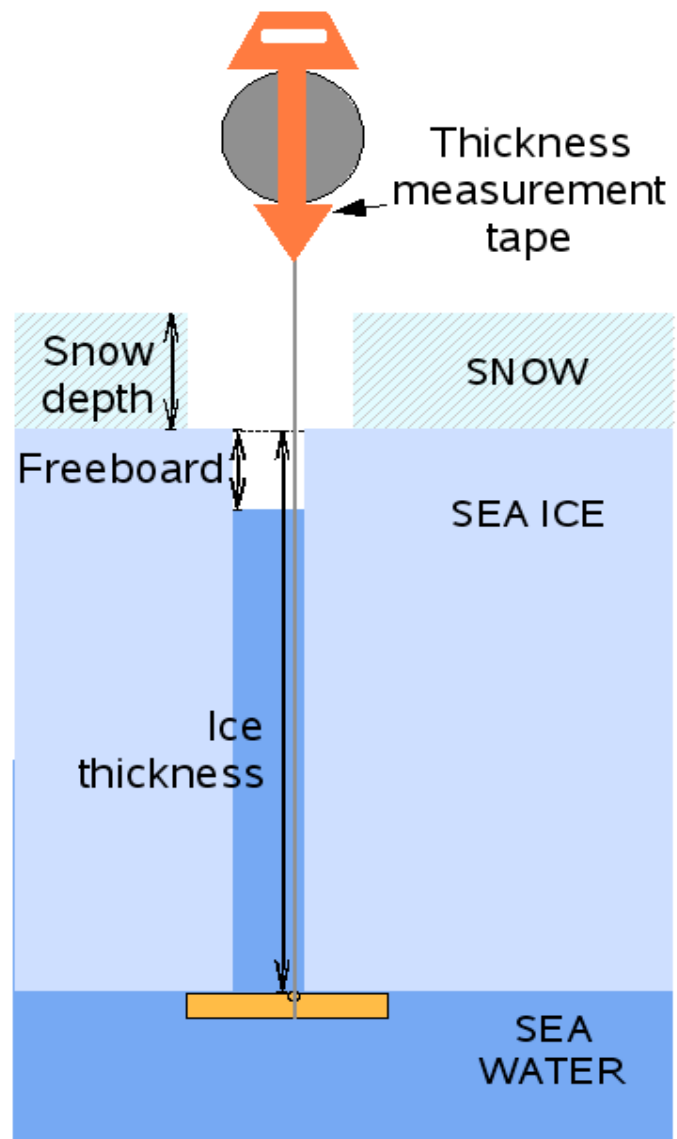

Figure 1 Measurement of ice thickness, freeboard and snow depth through a hole in the ice using a thickness measurement tape

1.4 Measuring snow depth, ice thickness, and freeboard

Snow depth, ice thickness, and freeboard can all be measured using the thickness tape, as shown in Figure 1. Unfold the brass weight and lower it down the hole in the ice until it is below the ice. Then, gently pull up on the tape so that the brass weight is up against the bottom of the ice.

Ice thickness is measured where the top of the ice meets the tape. Freeboard is the distance from the ice surface to the water surface. If the snow has been disturbed during drilling, measure the snow depth using a ruler somewhere near the hole. Once you have measured the ice thickness pull up a little harder on the tape and the brass weight should fold in half, allowing it to come up through the hole.

1.5 Measuring water depth

Water depth is simply measured by lowering the weight on the end of the water depth gauge through the hole until it is resting flat on the seabed. As the weight is lowered, you will feel it touch the bottom and then you will feel it lie flat (as shown in Figure 2). This is the position from which the water depth should be measured. Measure the water depth by first holding the cable just above where it goes into the water and slowly pulling in the cable until you see the first crimp. Measure this distance using the tape measure and then count the crimps on the cable as you wind the rest of it back onto its spool. The crimps are placed every meter. To help you keep count, there are two crimps placed close together every 5 m and three crimps close together every 10 m. Please don't forget to add on the distance from the waterline to the first crimp when recording the water depth. Finally, when back on land, please rinse the water depth gauge to reduce rusting.

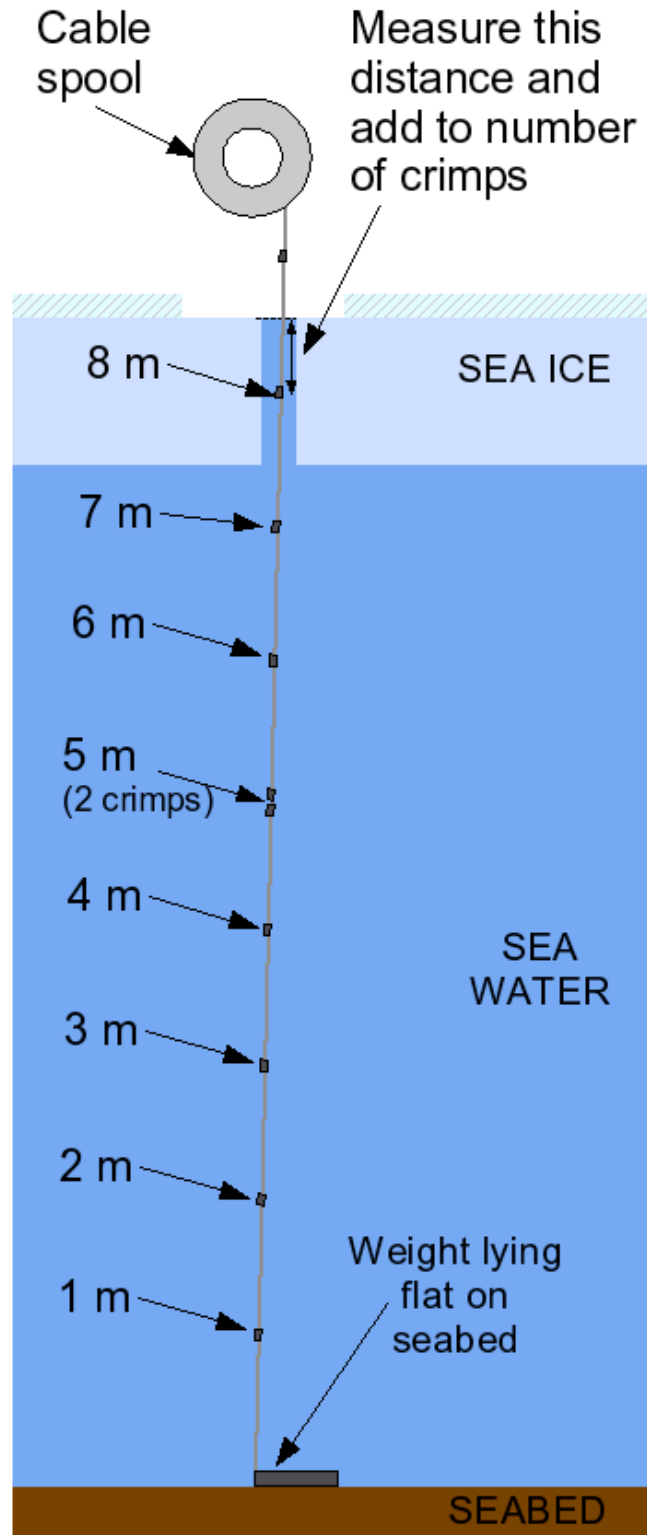

Figure 2 Using the water depth gauge through a hole drilled in the ice

Chapter 2: Installation of ice and snow measurement site

2.1 Before leaving land

Before leaving land, there are a few things that can be done that make life easier on the ice. The first of these is to place a nail through each snow stake at the level of last measurement mark. There should be a hole drilled through the stake at the right place. This nail rests on the ice and keeps the stake at the right place in its hole. Similarly, each ice thickness stake needs a nail or screw placed at the 0 m mark to hold it at the right height relative to the ice surface. A second nail or screw placed higher up the stake will make a useful hanger for the wooden handle of the hotwire cable, to keep it up out of the snow. Finally, the table below lists the items that need to be deployed and the tools that will be needed. This will allow you to check that all the right gear is on the sled before you leave for the sea ice. If possible, keep the bottle of water inside your jacket or wrapped in another parka to keep it from freezing.

Site components

- 4 wooden thickness stakes
- 4 hotwire cables
- 9 snow stakes
- 1 copper grounding wire
- 1 ground wire stake

Equipment required

- Kovacs auger; electric drill
- Extension power cord
- Generator
- Ice thickness tape measure
- Ruler
- Shovel
- Notebook / pencil
- Data recording sheet
- Bottle of water (~ 1 liter / 1 qt.)
- GPS
- Digital camera
- Water depth gauge

2.2 Choosing a site

Overall, the site should be located on sea ice that is regularly used by the community in an area that you judge is important for observing sea ice conditions. We leave overall site selection up to you, but it is best if the site occupies an area of level ice at least 200 m (200 yds) away from any large ridges. The site should also be relatively easy to reach, since you will be making several trips over the course of the winter and spring to

make measurements. Please remember to record the GPS coordinates of the site once it has been chosen.

2.3 Laying out the site

Having chosen a site, the next step is to lay out the locations for each of the four hotwire gauges and nine snow stakes that make up the measurement site. The layout and distances are indicated in Figure 3. Note that one edge of the grid should be aligned parallel to the prevailing wind direction.

The four outside corners of the site are marked by hotwire gauges 8 m (26 ft) apart. Inside these is a grid of nine snow stakes spaced 2 m (6 ft 6 in) apart. While measuring the site and drilling holes for the stakes, please make every effort to disturb the snow cover as little as possible. To avoid walking across the site, reach each snow stake from the edge. Also, having made footprints to reach the location of a stake, retrace these footprints if you need to return.

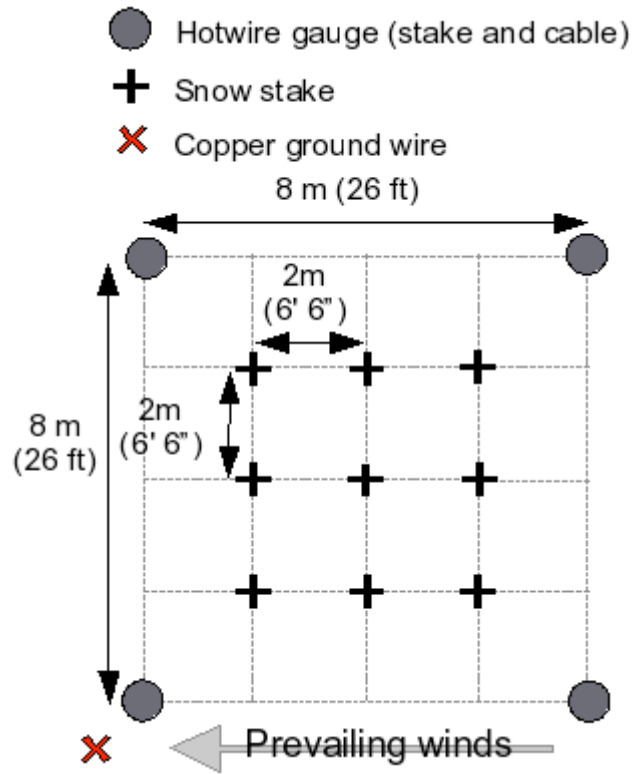

Figure 2 Lay out and dimensions of ice measurement site

2.4 Installing a hotwire gauge

Each hotwire gauge consists of a thickness stake and a cable. The thickness stake has a metric measurement tape on it. The cable has a wooden handle at one end and a metal bar at the other. Installation of these requires drilling two holes through the ice with the Kovacs auger, approximately 2.5 cm (1 in) apart. Take care that these holes are as close to vertical as possible. For each hole, measure the ice thickness, freeboard, and snow depth, as described in Chapter 1.

Place the stake into one hole as shown in Figure 4, ensuring that the screw at the 0 m mark (this will be some distance from the bottom of the stake depending on the length of the stake) rests on the ice surface, below the snow. Use snow to pack the hole above the water line to hold the stake vertical while it freezes in position. Next, hold the wood handle on the end of the hotwire cable and drop the metal bar through the other hole. Finally, hang the wooden handle up out of the snow using the second screw on the thickness stake.

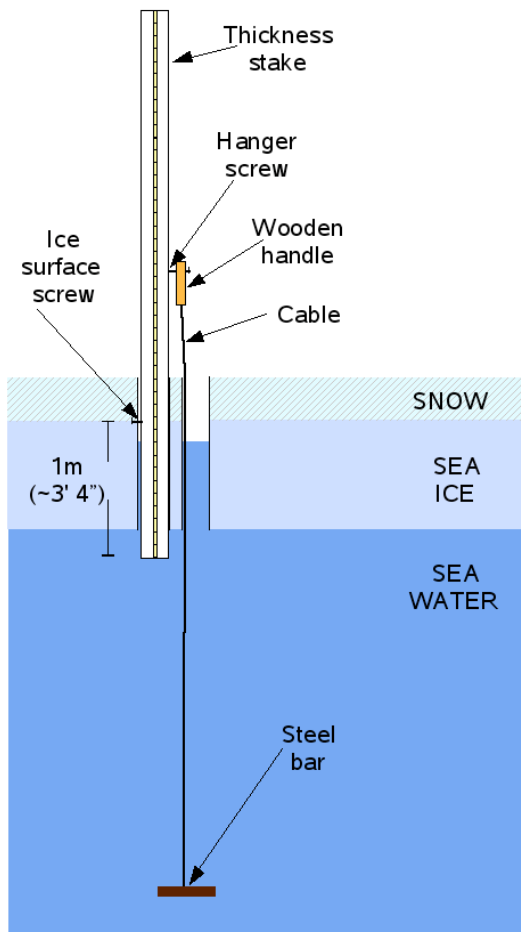

Figure 3 A hotwire gauge (stake and cable) placed in two holes through the ice

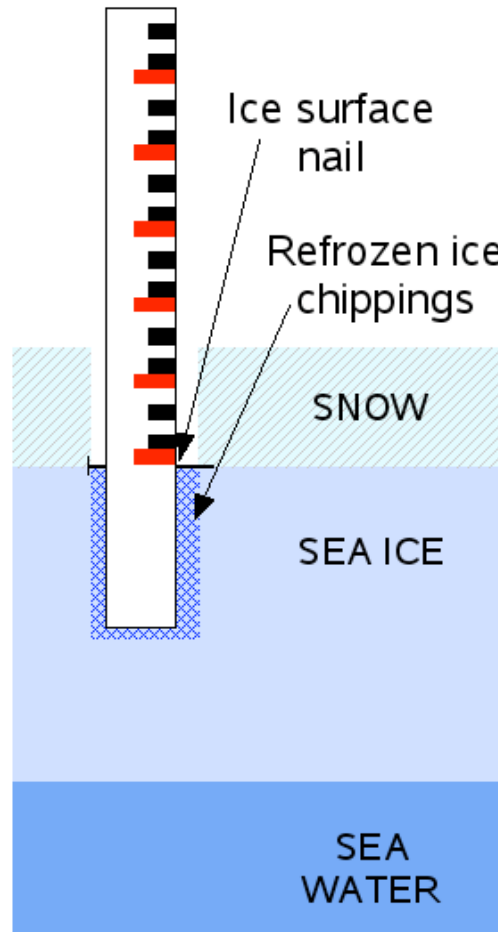

Figure 4 A snow stake in the ice placed in a shallow hole in the ice

2.5 Installing a snow stake

A snow stake only requires one hole at least 15 cm (6 in) deep. It disturbs the snow less if you do not drill all the way through the sea ice. Having drilled the hole, simply place

the snow stake inside so that the nail rests on the ice surface, as shown by Figure 5. Ensure each stake is vertical and facing such that their thinner edge is toward the prevailing wind and that all stakes are facing the same direction. This will make them easier to read and cause less snow to drift in behind each stake. This should also mean less scouring by the blowing snow, so the paint should last longer. Once properly aligned, pack the hole around the stake with ice chippings and add a little water from the bottle. Assuming it is cold enough, this should freeze solid quickly.

2.6 Installing the copper ground wire

Only one ground wire is needed per site and it should be placed just outside of the main square, near one of the corners. It requires a 3 m (10 ft) length of copper wire and a stake, similar to the snow stakes, but without the markings. You will need to place a nail through the hole drilled in the stake, just as with the snow stake (Section 2.5). To install the wire and stake, drill completely through the ice and lower the copper wire through the ice, leaving about 1 m (3 ft) above the ice. Then place the stake into the hole so that the nail rests on the ice and wrap the wire around the stake a couple of times, leaving a short piece sticking out, as shown in Figure 6.

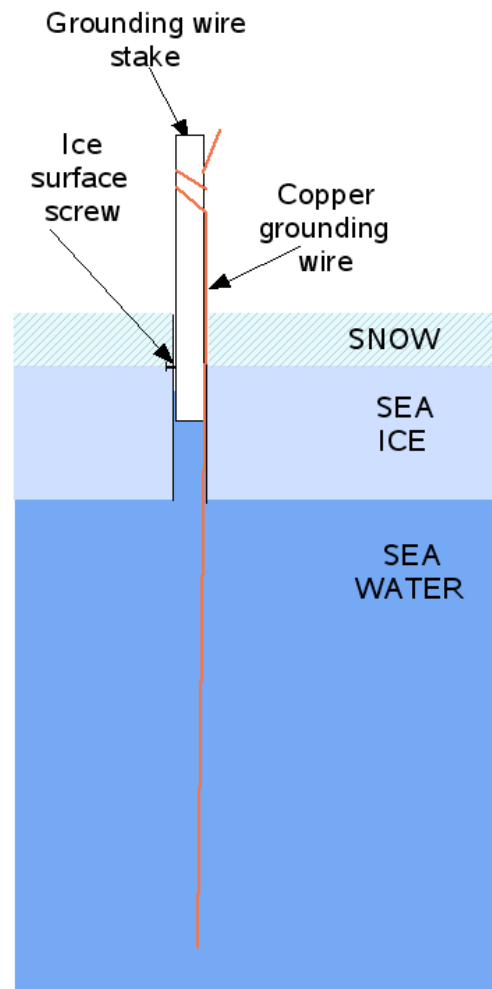

Figure 5 Installation of grounding wire and stake

Chapter 3: Hotwire measurements of ice thickness and snow depth

3.1 Before leaving land

Below is a checklist of what you will need to take measurements at the sites you have set up. It will save a little time to write the date on the recording sheet before heading out.

- Generator
- Variac (and spare fuses)
- Connector wires
- Data recording sheet
- GPS
- Digital camera

3.2 Reading the snow stakes

When arriving at the measurement site, be sure not to disturb the snow within the measurement area. The snow stakes are designed to be easy to read from a distance. If they are all facing the same way, you can stand in one place and take all the measurements. To take the measurement, count the number of black, white, and red marks that can be seen above the snow on each stake. Each mark is 2 cm wide. Red marks are 10 cm apart, as shown in Figure 7. If half a mark is covered up, count this as 1 cm. Record the length of each stake sticking out of the snow in the appropriate place on the data recording sheet. Also, please take a digital photo of the site, in which all the stakes can be seen. Feel free to take any other digital photos of the site or elsewhere during your trip.

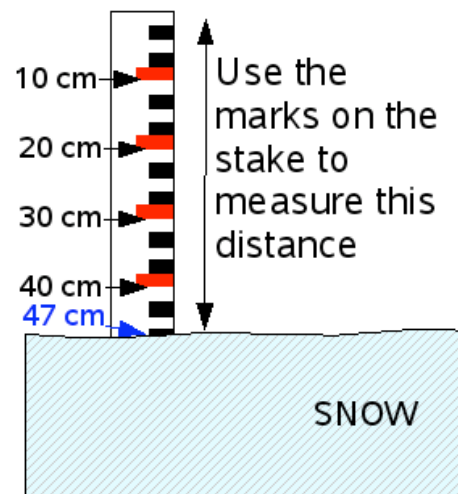

Figure 6 Measuring the length of the snow stake visible above the snow. The correct measurement in this case is shown in blue.

3.3 Measuring sea ice thickness with the hotwire gauges

In order to measure sea ice thickness, the hotwire cables need to be melted loose by running electric current through them. First, unwind the connector wires and connect one of the alligator clips to one of the hotwire cables and the other to the copper grounding wire (see Figure 8). Then, plug the connector wires into the Variac and connect the Variac to the generator. Before starting up the generator, make sure the Variac is switched off and the output voltage is set to zero. Now, start up the generator, switch on the Variac and gradually turn the voltage up to around 40 percent. Shortly, the hotwire cable should get hot and melt free so that it is possible to pull up on the metal bar at the bottom of the cable is tight up against the underside of the ice (Figure 9). Holding the handle against the measurement tape on the thickness stake, read the distance at the top of the handle, as shown in Figure 9, and write this down together

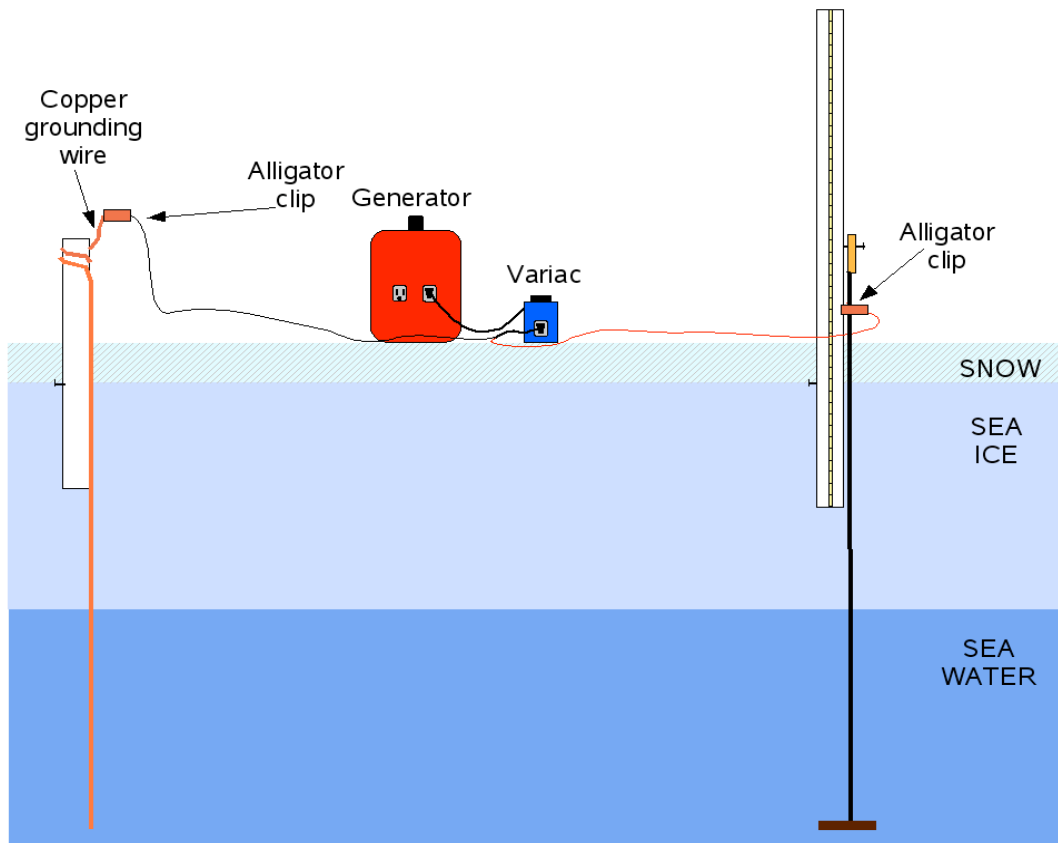

Figure 7 Connecting a hotwire cable and the copper grounding wire to the generator, through the Variac. The seawater beneath the ice completes the circuit and the current heats the cable so that it melts free.

with the stake number (written on the top of the stake) in the appropriate place on the recording sheet. If the cable is longer than the stake, use the ruler to measure the additional distance. When you have recorded the measurement, lower the gauge and hang the wooden handle on the hanger screw on the hotwire stake. This is very important as it prevents the bar at the bottom from becoming frozen into the ice. Repeat this for the other hotwire gauges. You can now shut off the generator and wind the connector wires anew.

Cautionary note for springtime measurements

During the spring, the surface of the ice may be flooded with meltwater from the snow. During this time, you should take extra care to keep the generator, Variac and cables out of the water. You may not even need to use the generator as the cables can melt free on their own.

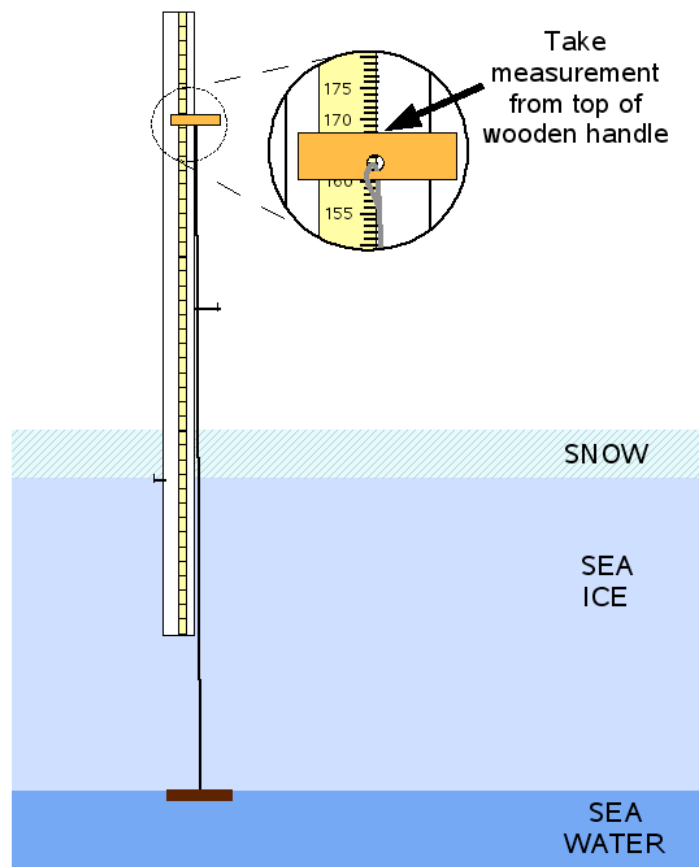

Figure 8 Pulling up on the hotwire cable and taking a measurement

3.4 Troubleshooting the hotwire gauges

If the hotwire gauges will not melt free, here are a few tips that may help solve the problem. Check that current is flowing by looking for sparks when the alligator clips are connected and disconnected.

If there is current flowing:

- Wait a little longer
- Turn the voltage up a little bit and try again
- Try a different hotwire cable

If there is no current flowing:

- Make sure both alligator clips are making good contact
- Make sure that the Variac is on
- Try a different hotwire cable
- Check the fuse in the Variac and replace if necessary
- Check the circuit breaker on the generator and reset if necessary
- Try connecting to a second hotwire cable instead of the copper grounding wire

If none of these suggestions work, the problem may be in the connector cables, which will be difficult to fix on the ice. Please complete the snow depth or ice melt measurements described in the next section and inform one of the project personnel of the problem.

3.5 Measuring snow depth or sea ice melt at the hotwire gauges

In addition to recording ice thickness with the hotwire gauges, please also record the position of the snow surface at the bottom of the stake, as shown in Figure 10. If the all snow has melted, record the position of the ice surface instead, as shown in Figure 11. Record this measurement in the box labeled “snow” for the appropriate stake on the recording sheet.

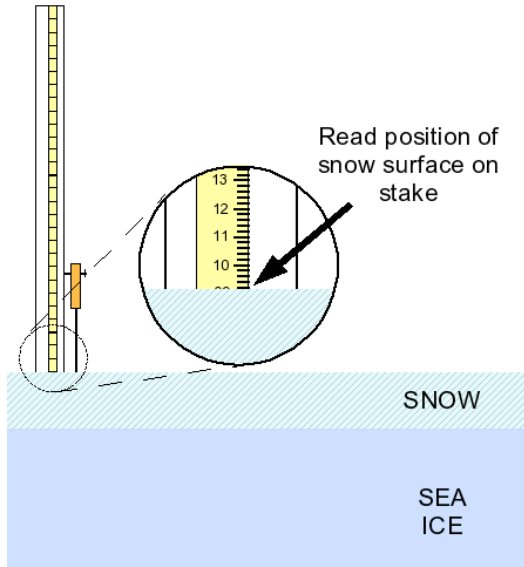

Figure 9 Measuring the position of the snow surface on the hotwire stake

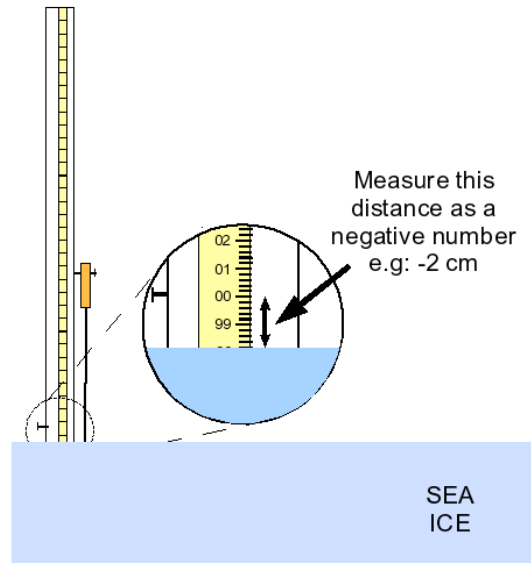

Figure 10 Measuring position of the ice surface after all the snow has melted

Chapter 4: Measuring sea ice surface and snow temperature

4.1 Before leaving land

This chapter describes how to measure the temperature of the sea ice surface and of the snow at different depths. The surface temperature of the sea ice under the snow and the temperature at different depths in the snow are useful for understanding how heat is flowing between the air and the sea ice. These measurements should be made during a visit to one of the ice thickness measurement sites. You will need the following additional equipment for making the temperature measurements, but please note that some items are already required for taking the snow and ice thickness measurements:

- Hand drill
- Probe thermometer
- Shovel
- Ruler
- Data recording sheet (see Appendix 2)
- GPS
- Digital camera

4.2 Digging a snow pit

To take the measurements, you will need to dig a small pit in the snow to expose the surface of the ice. Before digging the pit, look for an area of undisturbed snow. After exposing the ice surface, use the shovel to make a nice clean, vertical wall on one side of the pit.

4.3 Measuring ice surface temperature

To measure the temperature of the sea ice, the temperature probe will have to be placed into the ice so that it is not being affected by air temperature. For this you will need to drill a small hole in the ice using the hand drill. Drill the hole at a 45° angle so that the probe remains closer to the surface of the ice (as shown in Figure 12). Place the

temperature probe in the ice and allow the temperature reading to stop changing before recording the value on the recording sheet.

4.4 Measuring snow temperature

We recommend measuring the snow temperature every 5 cm from the bottom of the snow. This is also shown in Figure 12. As with the ice, the thermometer needs to be left in the snow until the temperature stops changing. When recording the snow temperatures and distances on the recording sheet, please remember to count upwards from the ice surface, rather than downwards from the top of the snow. Please also record the total snow depth.

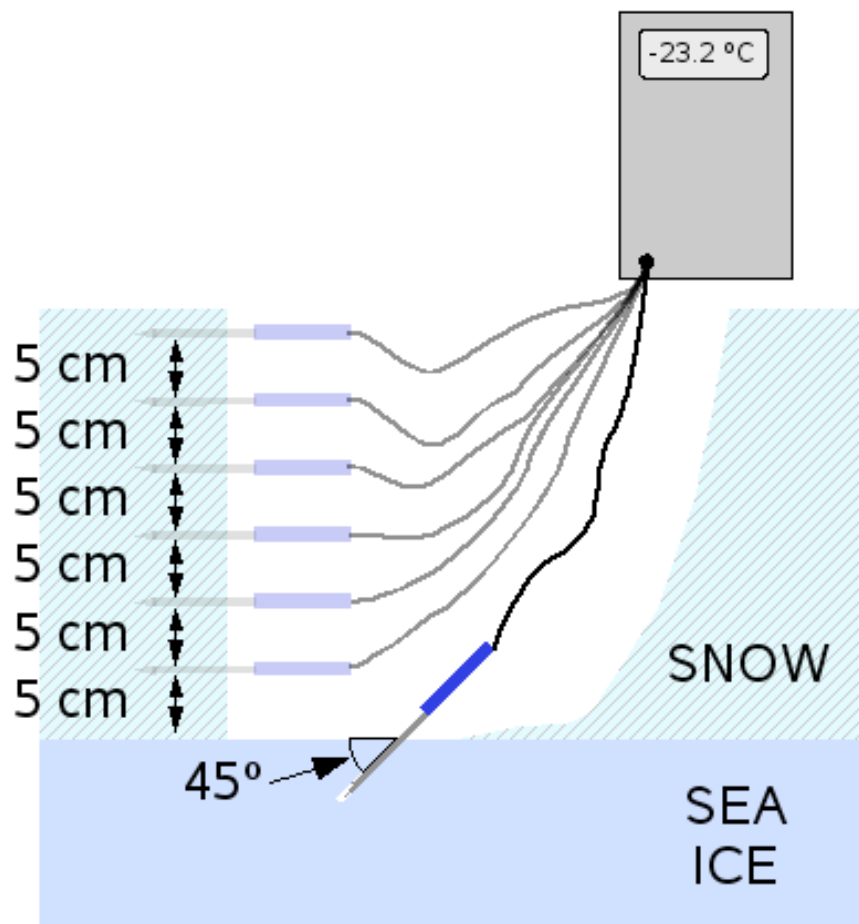

Figure 11 Measuring ice surface temperature and snow temperature in a snow pit

Chapter 5: Retrieving the stakes and cables

5.1 Before leaving land

Please read the information below about when to retrieve the equipment and how to do so. You may need a pair of wire cutters.

5.2 When and how to retrieve the equipment

The decision of when to remove the stakes and cables at the end of the sea ice season is a balance between measuring as much melt season as possible and ensuring the safe retrieval of the equipment. This will be your decision and will no doubt be different from year to year. If left late enough, the stakes should pull out of the sea ice easily. The cables may need heating to become loose if the ice is still cold at depth. Without chipping or cutting large holes in the ice, you will not be able to pull the cable out with the weight on the end. Hopefully, with a strong enough pull, the weight should slip off and sink to the sea bed allowing you to pull the remaining cable out to be used next year with a new weight. If the weight will not slip off, the cable will need to be cut and you will need to make new cables with weights for the next year.

5.3 Storage during summer

To minimize rusting during the summer, which may damage the equipment, please rinse all metal items (auger, cables, depth gauge, etc.) in freshwater and allow to dry before storing. For the stakes, please store away from direct sunlight to preserve the paint and tape.

Chapter 6: Simple Data Analysis

The data collected from the measurements described in this handbook can be used to calculate growth and melt rates of the sea ice and accumulation and ablation of the snow on top. The snow and ice temperature data can also be used to constrain simple growth models that can help show other thermal processes taking place underneath the sea ice. The simplest form of data analysis involves calculating the sea ice thickness and snow depths from the “raw” field measurements. This involves simply subtracting the field measurement from the total cable length or stake length. This is why it is so helpful to have all the hotwire cables the same length.

It is important to note that the hotwire measurements do not strictly measure sea ice thickness. They measure the position of the bottom of the sea ice relative to the position of the sea ice surface when the gauge was deployed. If there is no surface melt (and no accumulation of sea ice on top due to flooding), this measurement will directly give the sea ice thickness. However, if the position of the surface changes (due to surface melt or flooding and refreezing) then this needs to be accounted for to calculate the total sea ice thickness. The advantage of this method is that it makes it possible to differentiate between changes taking place at the upper and lower surfaces of the ice, which would be missed by simply measuring ice thickness. This is most useful in spring when it is possible to measure thinning of ice from above and below.

To accompany this handbook we have provided an example spreadsheet for entering the raw field data. This is available at:

<https://nsidc.org/sites/default/files/documents/other/dataentry.xlsx>. If the hotwire cable and snow stake lengths are entered, the spreadsheet conveniently calculates the corresponding ice thicknesses and snow depths. There are also formulas for calculating means and charts that will plot the data as you enter them. The spreadsheet contains tables for entering all the data collected from a single station, but can be extended for multiple stations.

For a more complicated analysis of the data, your project might consider collaborating with another sea ice scientist. For assistance, contact the National Snow and Ice Data Center at nsidc@nsidc.org.

Appendix 1 : Constructing the necessary equipment

6.1 Making a snow stake

Snow stakes are easy to make, but require careful measurement, cutting, and painting. Each snow stake is made from a piece of 1"x2" dimensional lumber. The length of the stake depends upon how much snow you expect. The stakes need to be longer than the deepest snow with ~20-30cm extra for planting in the ice. Nine stakes are required per site and they need to be painted white to minimize any melting they may cause by absorbing heat from the sun.

Next comes the tricky part. Each stake needs black and red "tick marks" painted along one edge. Each black tick mark needs to be 2 cm wide and spaced alternately at 4 cm and 6 cm intervals. Each red tick mark is also 2 cm wide and spaced at 10 cm intervals. A total length of 60 cm should be marked with these ticks. This is illustrated in Figure 13. The easiest way to achieve this is to create a stencil and make the tick marks with spray paint. On the next page, there is a template that can be used for making stencils for each color of tick mark. You will need to print and join multiple copies depending how long you make your snow stakes

Finally, once the stake has been completely painted, drill a pilot hole for a nail in the side of the stake and level with the bottom of

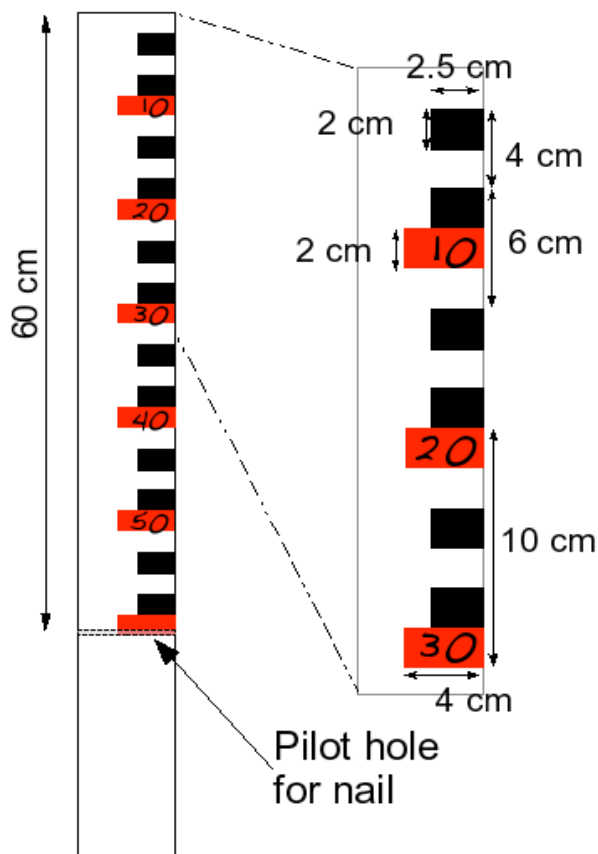

Figure 11 Detailed measurements for tick marks on snow stakes

the lowest red tick mark, as indicated in Figure 13. A nail placed in this hole will ensure the stake sits at the correct height when it is frozen into the ice.

You will also probably find it useful to label the red tick marks using a permanent marker, as shown in Figure 13. To protect the stake from blowing snow, which will strip the paint quite quickly, we recommend wrapping the stake in some kind of adhesive plastic. Heavy-duty clear plastic tape will work if applied in a spiral, ensuring good overlap between turns.

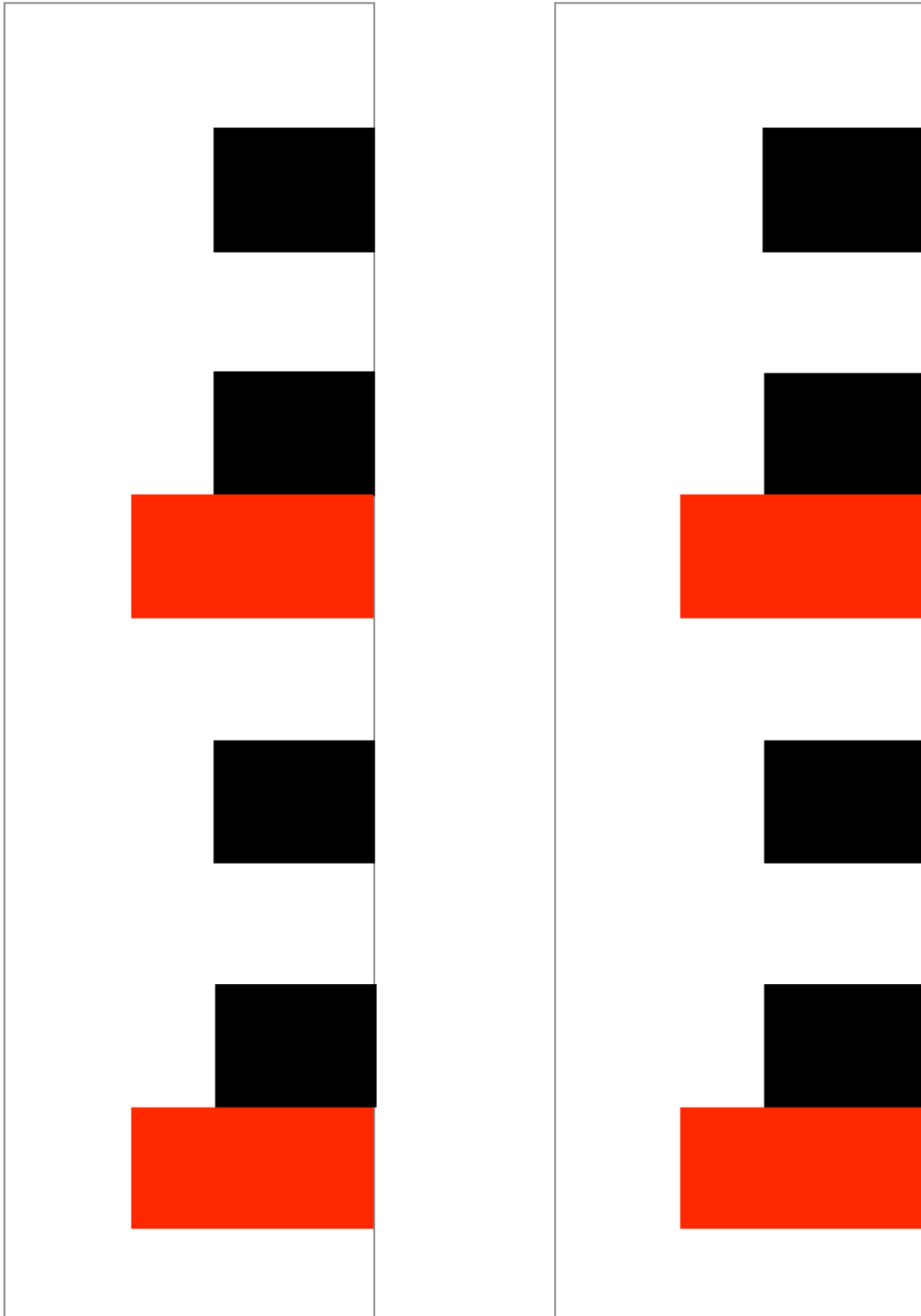

Figure 12 Templates for stencils for spray-painting tick marks on snow stakes. You will need to join three of these templates together to create a stencil long enough to paint all the tick marks for a stake.

6.2 Constructing the stakes for the hotwire gauges

The stakes for the hotwires are very simple. Each one consists of a 3 m (or as long as you can find) length of 2 ft by 2 in dimensional lumber, painted white with some adhesive metric tape stuck to one side. The white paint helps the stake reflect the sunlight in spring and reduce artificial melting around the stake. The adhesive metric tape is used to take the measurements. The tape needs to extend below the 0 m mark so that you can measure the amount of surface melt in spring.

Adhesive metric tape is typically only marked in centimeters (i.e., it starts again every meter) so it will be useful if you write the number of meters on the stake using a permanent pen. If you cannot get adhesive metric tape, staple a 3 m section of a cheap measuring tape to the stake. In this case, please be sure to mark the correct number of meters on the stake with the 0 m position 1 m from the bottom of the stake. Lastly, don't forget to number your stake. Each station has four stakes and we use a system that includes two numbers to indicate the station number and the stake number. For example, "2-3", would be station 2-stake 3. "1-4", would be station 1-stake 4, and so on.

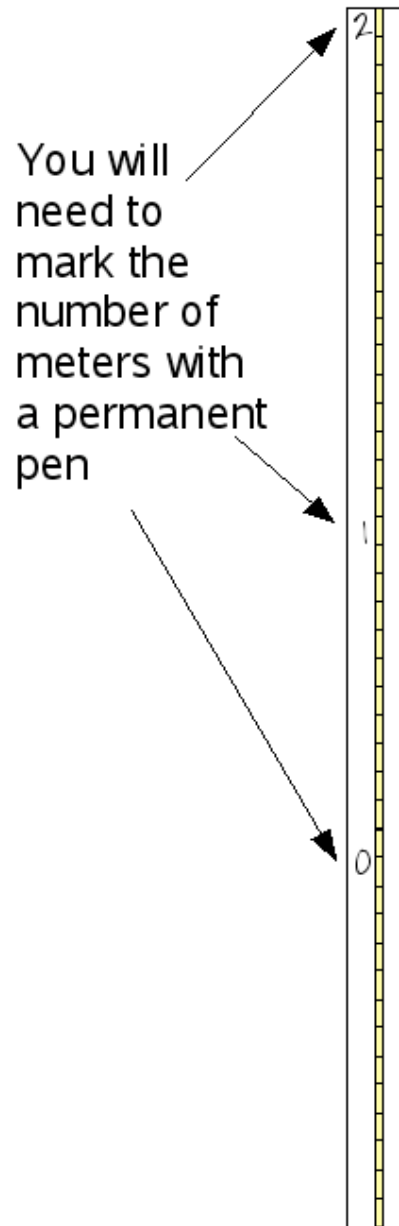

Figure 13 A stake for a hotwire gauge is a 3 m length of wood, painted white with adhesive metric tape stuck on one side.

To protect the stake from blowing snow, which will strip the paint quite quickly, we recommend wrapping the stake in some kind of adhesive plastic. Heavy-duty clear plastic tape will also work if applied in a spiral around the stake ensuring good overlap between turns.

6.3 Constructing the cables for the hotwire gauges

The hotwire cables are also a simple design, but the diameter of the cable is quite critical. A 1/16 in cable is too thick. It conducts the current too efficiently to heat up and melt free. It can be difficult to find thinner cable than this, but a rope and rigging store should sell 3/64 in or 1/32 in cables. Be sure to buy crimps of the correct size for the cable.

Each hotwire cable needs to be cut to the right length, depending on maximum thickness of the sea ice and depth of the snow in the area. The cable needs to be long enough that the top will be above the deepest snow and the bottom will still be below the bottom of the thickest ice. Typically cables are 2 to 3 m (6 ft, 6 in to 10 ft) when assembled and you should cut approximately 20 cm (7 in) extra for attaching the handle and weight.

On one end, attach a wooden handle made out of a short length of scrap wood and attach it to a loop in the cable secured with two crimps, as shown in Figure 17. Now attach a steel bar to the other end to act as a weight and as a measuring surface. The bar should weight at least 300 g (10 oz) and needs a hole drilled as shown in Figure 15. We want the bar to rest flat against the underside of the ice when the cable is pulled up, so the crimps must be placed below the bar, as shown in Figure 15. Now measure the distance from the bottom of the weight to the top of the hand and write this length on the handle. We strongly recommend making all your cables the same length.

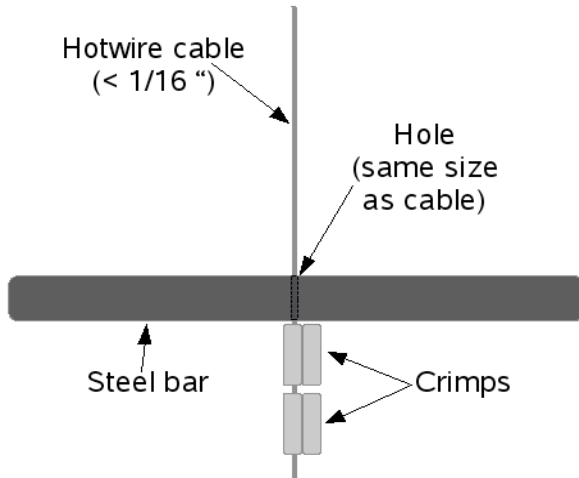

Figure 14 Steel bar attached to bottom of hotwire cable

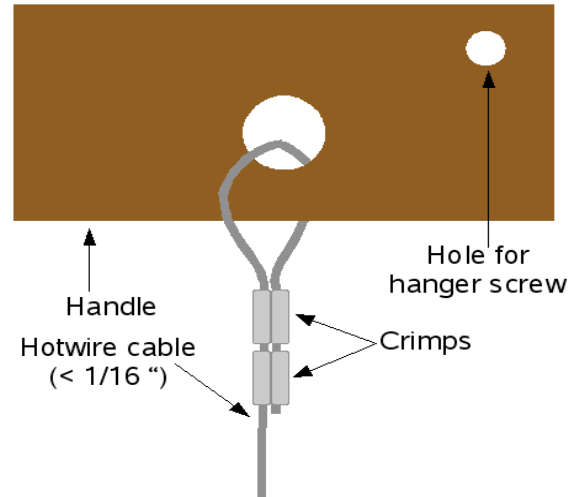

Figure 15 Wooden handle attached to one end of hotwire cable

6.4 Making the connector wires

The connector wires are used to connect the hotwire cables to the Variac. They consist of two 8 m (25 ft) lengths of cable, each with an alligator clip at one end and joined at a regular 120 V plug at the other end. The cable need only be 8 or 10 gauge, but it is important to get cable that remains flexible in cold temperatures (e.g. Arctic Ultraflex Blue from www.polarwire.com). It is also very useful to have a spool for these wires.

6.5 Building a water depth gauge

The water depth gauge consists of a 50 m length of cable (1/16 in to 1/8 in or 1.5 to 3 mm) with a heavy weight attached to one end. The weight has to be heavy enough to prevent the cable from drifting in under-ice currents and yet also be able to fit through a 5 cm hole made by the Kovacs auger. For this reason, the weight should be a length of thick steel (or lead, but steel is easier to come by) bar. This design also allows one to feel when the weight is lying flat on the sea bed (there

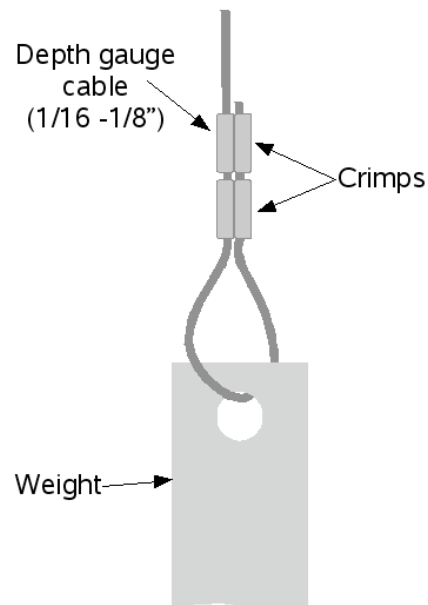

Figure 18 Attachment of weight to end of depth gauge cable

will be an initial unloading of weight when the tip of the weight touches the sea bed, and a second unloading when the weight is lying flat). A 30 to 50 cm section of 1 in (2.5 cm) bar should be fine. Having obtained a suitable weight, make a hole in one end large enough to pass the cable through. Use crimps to secure the weight to a loop on the end of the cable as shown in Figure 18. Then place crimps at 1 m intervals, measured from the hole in the weight, along the length of the remaining cable. Every 5 m, place two crimps close together, and three crimps every 10 m (as indicated in Figure 2).

6.6 Hardware recommendations

- **Ice auger:** we strongly recommend the 5 cm ice auger from Kovacs Enterprises (www.kovacsicedrillingequipment.com).
- **Ice thickness gauge:** Kovacs Enterprises also sells an ice thickness gauge.
- **Generator:** we suggest something portable with an output of at least 2000 W.
- **Extension cable:** cold weather rated extension cables that stay flexible in cold temperatures will make life a lot easier.
- **Variac:** a robust, 120 V AC variable transformer rated to at least 10 A.
- **Adhesive measuring tape:** try www.boreal.com.
- **Thermometer:** there are many different types of digital thermometers available. One example is www.daigger.com.

Appendix 2 : Data Recording Sheets

The following three pages contain sheets to be used for recording measurements taken on the sea ice. The “drill hole ice data recording sheet” can be used to keep track of data anytime you drill a hole in the ice and take measurements using the methods described in Sections 1.4 and 1.5. You do not use this sheet for monitoring the stations you put into the sea ice, though it is useful to use the very first time you put the station in and you take GPS and water depth readings.

The other two sheets, “Hot wire gauge and snow stake recording sheet” and “Ice and snow temperature data recording sheet” are the sheets that you need to bring out each time you take measurements at your sea ice stations. You will need these two sheets for every station you visit—if you have four stations, you will have a total of eight sheets. Make sure to bring enough sheets, and a pencil!

When you return from taking your measurements, be sure to file the sheets in a safe place or give them to your project coordinator. It is always a good idea to make copies of the data sheets and keep them in separate locations to be safe.

Hotwire gauge and snow stake data recording sheet

Name: _____ Notes: _____

Date: _____

Location: _____

1

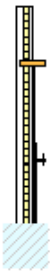

Cable

:

Snow:

2



Cable

:

Snow:

1

Snow:



2

Snow:



3

Snow:



Temperature:

Air
<input type="text"/>
Ice
<input type="text"/>

4

Snow:



5

Snow:



6

Snow:



7

Snow:



8

Snow:



9

Snow:



3

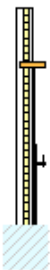

Cable

:

Snow:

4

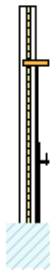

Cable

:

Snow:

Ice and snow temperature data recording sheet

Name: _____ Date: _____		Notes:
Air temperature (°C): _____ Ice temperature (°C): _____		
<i>Snow temperature measurements:</i>		
Distance above ice surface (cm)	Snow temperature (°C)	
5		
10		
15		
20		
25		
30		
35		
40		
45		
50		
55		
60		
65		
70		
75		
80		
85		
90		
95		
100		

Appendix 3 : Sea ice monitoring in action



Mamarut Kristiansen of Qaanaaq, Greenland demonstrates the Kovacs auger attached to an electric drill, powered by a generator. The drill is a quick and easy way to measure sea ice thickness with measuring tape (Chapter 1) and install the permanent stakes of the monitoring stations (Chapter 2). Photo: Shari Gearheard

Handbook for community-based sea ice monitoring



Clyde River residents Teema Qillaq, Andy Murray, and Lasalie Joanasie install a sea ice monitoring station near Clyde River in Nunavut, Canada (see Chapter 2). Photo: Nina Palitug



Placing snow stakes for a monitoring station near their community of Qaanaaq, Greenland, Andy Mahoney and Mamarut Kristiansen insert a snow stake into a hole in the ice, taking care to ensure it is vertical. In the background, Joe Leavitt drills a hole for another stake. Photo: Shari Gearheard



Ilannguaq Qaernгааq and his dog team travels over the sea ice to take observations at one of the Qaanaaq monitoring stations in Greenland. Photo: Toku Oshima



Paulus Simigaaq walks back to Qaanaaq with the equipment needed for the hotwire measurements. The generator is left running to stay warm. Photo: Toku Oshima



Above left: A hotwire gauge with handle hanging on nail above the snow. Photo: Teema Qillaq.
Above right: Toku Oshima and Teema Qillaq pull up on a heated hotwire cable and measure the length of the cable, as described in Section 3.3. Photo: Andy Mahoney



Shari Gearheard at a monitoring station near the community of Clyde River in Nunavut, Canada. The flags help people see the station from a distance. Local ice monitor Teema Qillaq added the flags and recommends reflective tape on the stakes. Shari stands next to a sign in Inuktitut and English that explains what the station is for and gives a contact number in the community for questions. The sign also asks people to not walk within the site (though as you can see it doesn't stop local sled dogs!). The sign post doubles as a place to secure the ground wire (Section 2.6) Photo: Teema Qillaq.



Clyde River sea ice monitor Teema Qillaq uses a hand drill to make a hole in the sea ice for measuring ice temperature (see Section 4.3). Photo: Nina Palituq

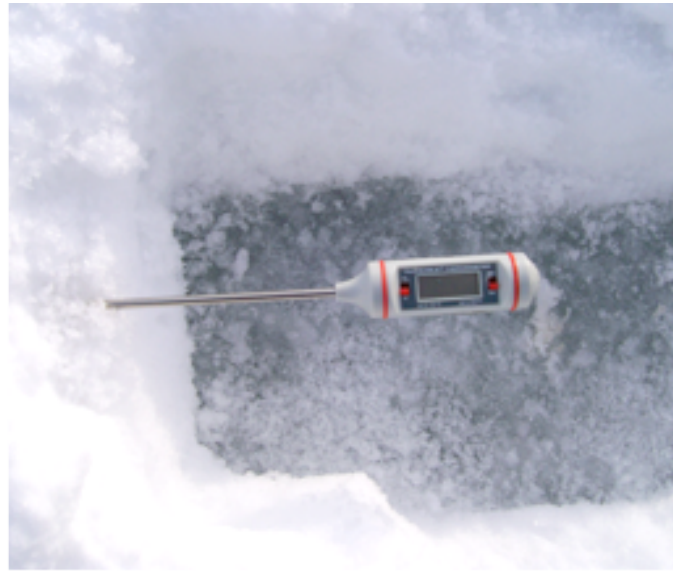

Above left: A digital thermometer inserted into a hole at a 45-degree angle to measure surface sea ice temperature (Section 4.3 and Figure 12). Above right: A digital thermometer inserted horizontally into the snow 5 cm from the ice surface (Section 4.4 and Figure 12). Photos: Nina Palituq